

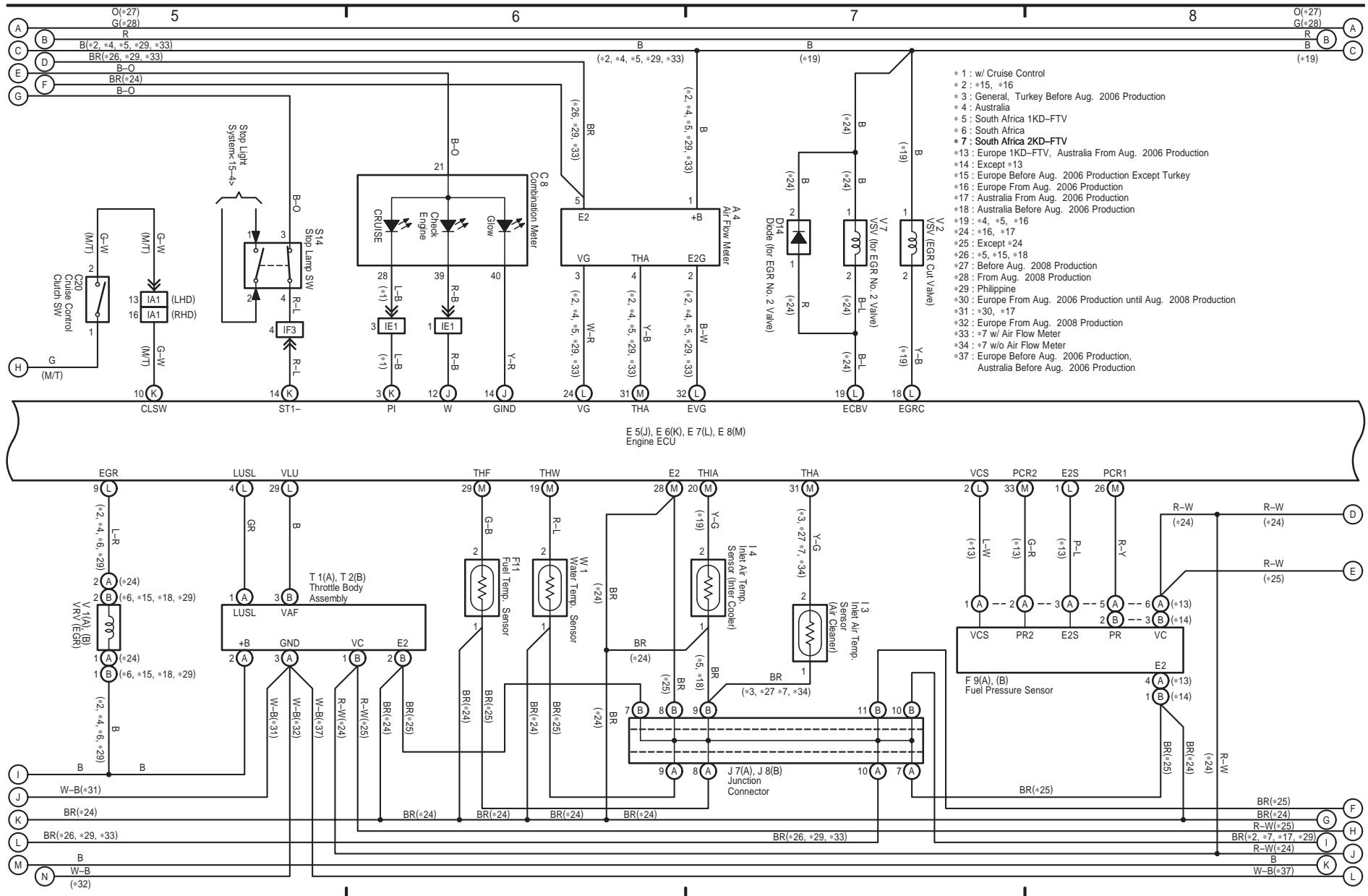

Engine Control (1KD-FTV, 2KD-FTV)



- \* 1 : w/ Cruise Control
- \* 2 : \*15, \*16
- \* 3 : General, Turkey Before Aug. 2006 Production
- \* 4 : Australia
- \* 5 : South Africa 1KD-FTV
- \* 6 : South Africa
- \* 7 : South Africa 2KD-FTV
- \* 13 : Europe 1KD-FTV, Australia From Aug. 2006 Production
- \* 14 : Except \*13
- \* 15 : Europe Before Aug. 2006 Production Except Turkey
- \* 16 : Europe From Aug. 2006 Production
- \* 17 : Australia From Aug. 2006 Production
- \* 18 : Australia Before Aug. 2006 Production
- \* 19 : \*4, \*5, \*16
- \* 24 : \*16, \*17
- \* 25 : Except \*24
- \* 26 : \*5, \*15, \*18
- \* 27 : Before Aug. 2008 Production
- \* 28 : From Aug. 2008 Production
- \* 29 : Philippine
- \* 30 : Europe From Aug. 2006 Production until Aug. 2008 Production
- \* 31 : \*30, \*17
- \* 32 : Europe From Aug. 2008 Production
- \* 33 : \*7 w/ Air Flow Meter
- \* 34 : \*7 w/o Air Flow Meter
- \* 37 : Europe Before Aug. 2006 Production, Australia Before Aug. 2006 Production

HILUX (EM00L3E)

Engine Control (1KD-FTV, 2KD-FTV)

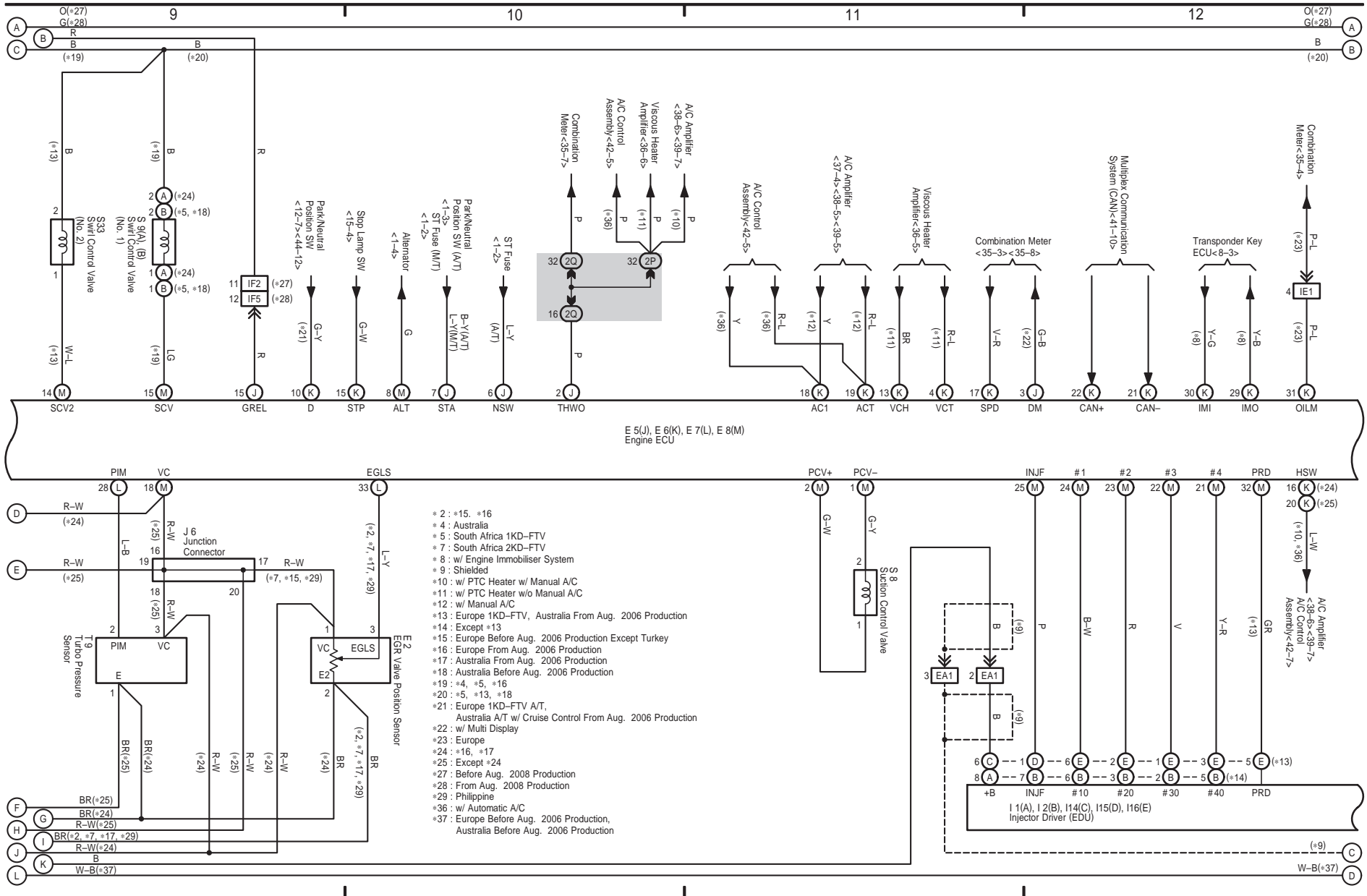

Engine Control (1KD-FTV, 2KD-FTV)

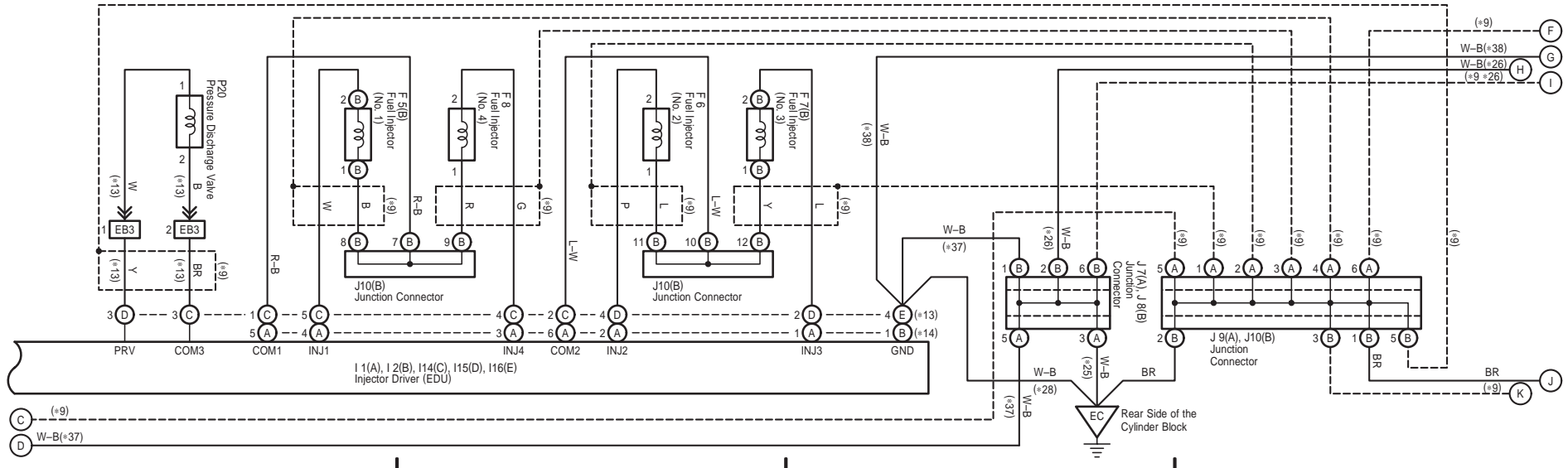
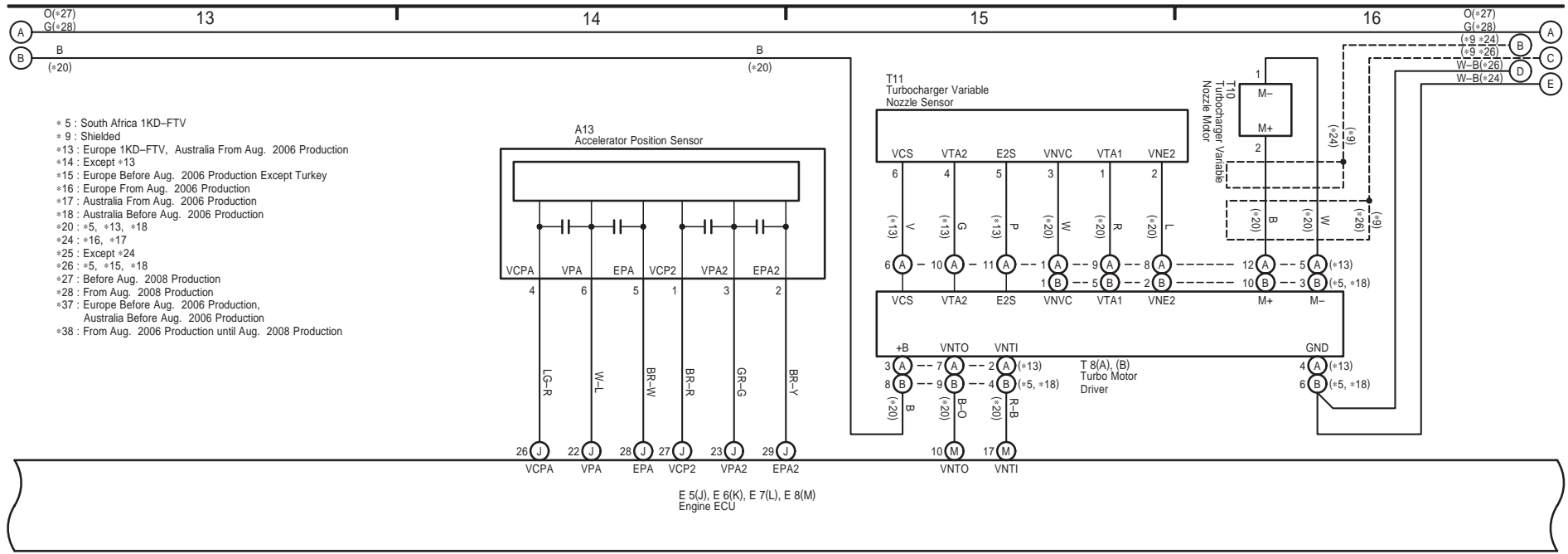

HILUX (EM00L3E)

6 HILUX (Cont' d)

Engine Control (1KD-FTV, 2KD-FTV)

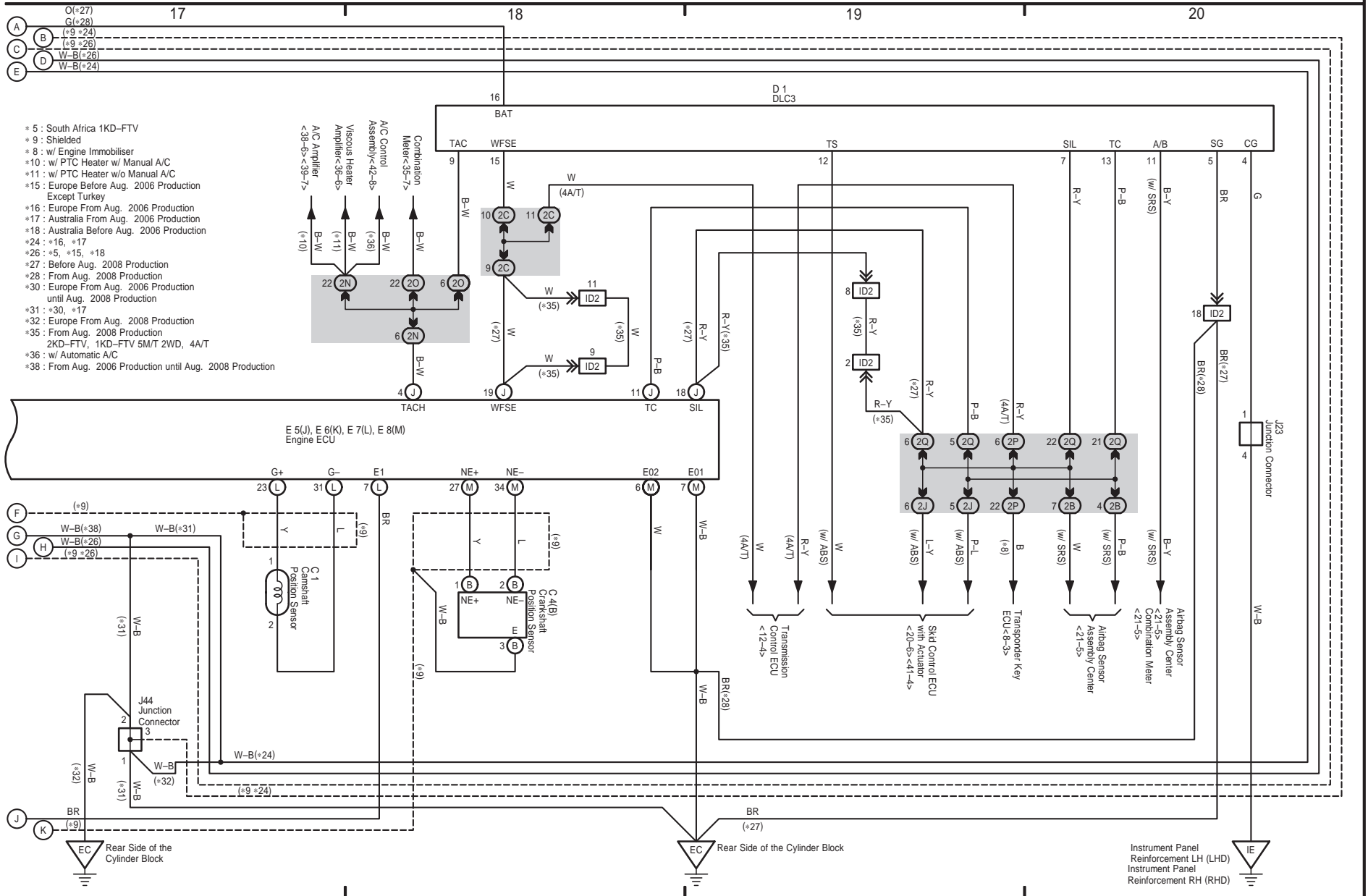

HILUX (EM00L3E)